

# CLEANBELT®

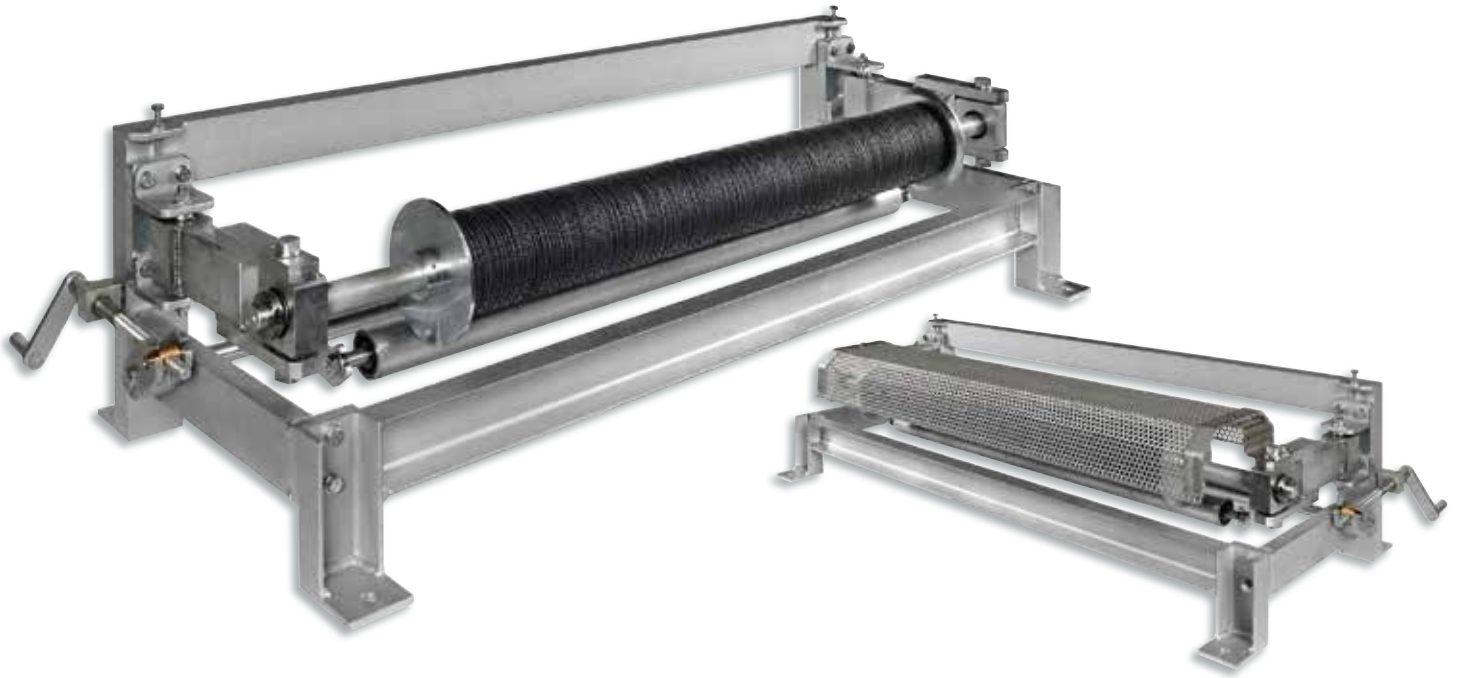

Cleaning System For  
STEINHAUS Rolled Baking Oven Belts

 **STEINHAUS**



The maintenance free CLEANBELT cleaning system has been specifically developed for rolled baking oven belts made by Steinhaus.

The spiral structure of our rolled baking oven belts is equal, with good angularity and always with the same number of spirals along the whole belt length. This advantage of the invariable mesh number is used by CLEANBELT in breaking the dirt in the belt's mesh structure without missing a mesh. The oven's brush systems to follow can then, if used adequately, remove the dirt better and more effectively. Problems in daily operation caused by soiled baking oven belts such as detracted air circulation in the oven, increased costs for heat management, reduced flexibility and operational lifetime of the belt - all these adverse effects will be counteracted successfully by the CLEANBELT system in combination with the existing oven's brushes.

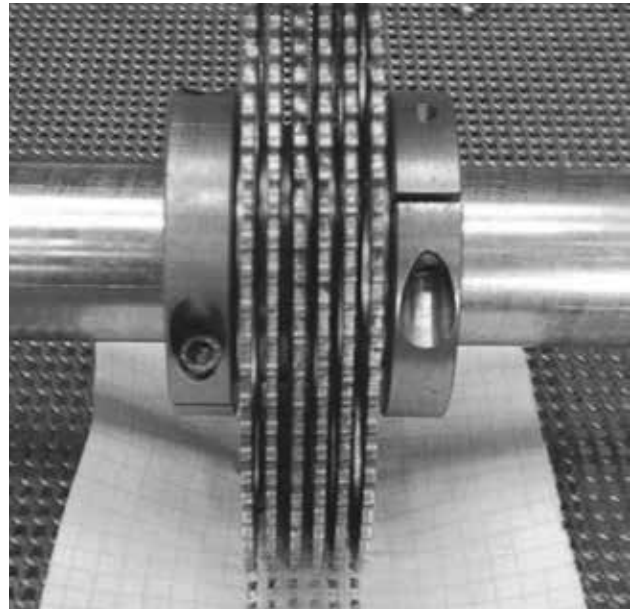

## Advantages

- The system works continuously and mechanically nearly maintenance free (only regular cleaning by compressed air or jet water)
- Additional manual cleaning of the baking oven belt is either no more necessary or reduced to a minimum at much greater intervals
- Improved oven's heat management at reduced costs
- Considerably reduced energy consumption for heating
- Longer operational life time, since no more belt changes because of dirt
- Suitable for several belt life time cycles
- Easy installation since no electric components involved
- Investment pays off in a short time

## References

- Developed by and in cooperation with our French partner TMFCT, an experienced service company for the baking industry, CLEANBELT systems have been operating successfully since more than 7 years to the great satisfaction of our clients. By now (summer 2018), our cleaning systems is installed in more than ~70 tunnel ovens in ~18 countries worldwide.
- Among our clients are companies, well-respected in the baking world, in countries like: Germany, France, Italy, Spain, Greece, Russia, Poland, Czechia, Indonesia, Malaysia, Japan, Switzerland, Tunesia, etc. ...

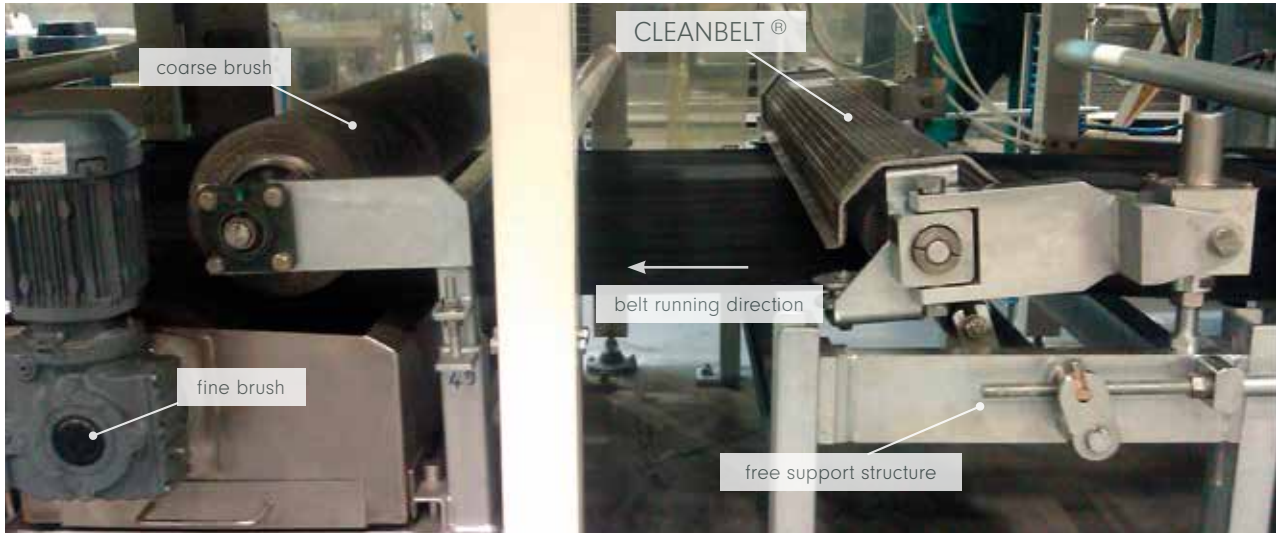

## Mode of Operation

The CLEANBELT cylinder consists of individually mounted sprocket discs combined with intermediate distance rings, which are tuned to the individual mesh structure of each belt. So they work themselves exactly into the mesh opening. The sprocket discs can break up the (cake of) dirt, stuck to the belt's surface and/or in the belt meshes. So that the existing brush system, following the CLEANBELT, can finally remove it.

The whole system is (nearly) maintenance free and is cleaned, if necessary, by compressed air or jet water. The system is self-driven since the sprocket discs of the CLEANBELT cylinder follow the row of meshes of the running belt.

No electrical installation is necessary.

For each free running and unguided belt there are certain movements in the belt's tracking. Consequently they appear, although to a lesser degree, also with our rolled baking oven belts. To equal these running variations the CLEANBELT system is freely supported on a stand-alone frame structure and can follow independently the belts (slight) movements to left and right.

Our experiences from the field have shown that for many brush systems in operation there is a big potential for improvement, too. Gladly we could offer some assistance in this respect in order to achieve in combination with CLEANBELT the best possible cleaning result for your belt.

## Build-in Situation

The arrangement of the CLEANBELT system together with existing brushes is to be done as per the sketch shown on the right.

Between CLEANBELT and brushes there must be no rollers for support or whatsoever. Otherwise the broken dirt layer would be pressed back into the meshes of the baking oven belt. For an optimum cleaning result there should be first a (self running) coarse brush from above and then a fine brush from below (motorized to run in counter direction).

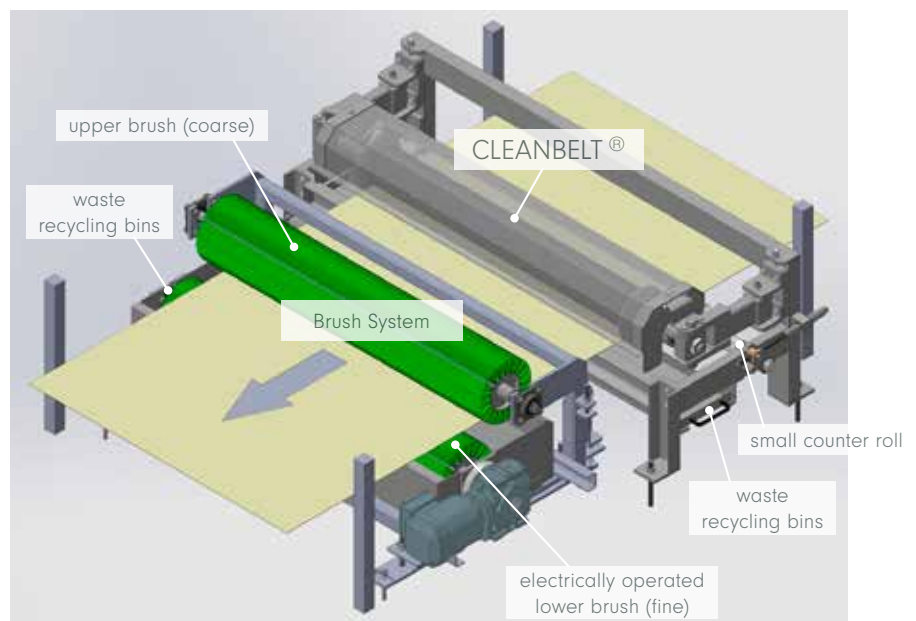

## Scope of delivery

The CLEANBELT system consists of the following components:

### Main parts

- CLEANBELT cylinder with sprocket discs and distance rings
- Stand-alone frame structure with free cylinder support, counter roller and levelling crank
- Safety protection grid
- Dust bin tray

For our offer to you we need the following information:

- Actual belt width, measured at 3 different places of the belt
- Number of meshes over the whole belt width
- Alternatively order and references numbers of our belt supply
- Photo of intended build-in place close to the brush system

Our team is also available to do a first oven checking together with you.



CLEANBELT without safety protection grid



The free support frame structure for the CLEANBELT for following the belt movements

 **STEINHAUS**

STEINHAUS GmbH  
Platanenallee 46  
45478 Mülheim an der Ruhr  
Germany

Phone +49 208 / 58 01 - 01  
export@steinhaus-gmbh.de  
www.bakingovenbelts.com

