

# Rolled Baking Oven Belts

## Z-Belts



**CLEANBELT<sup>®</sup>**  
Cleaning System For Z-Belts



# Rolled Baking Oven Belts

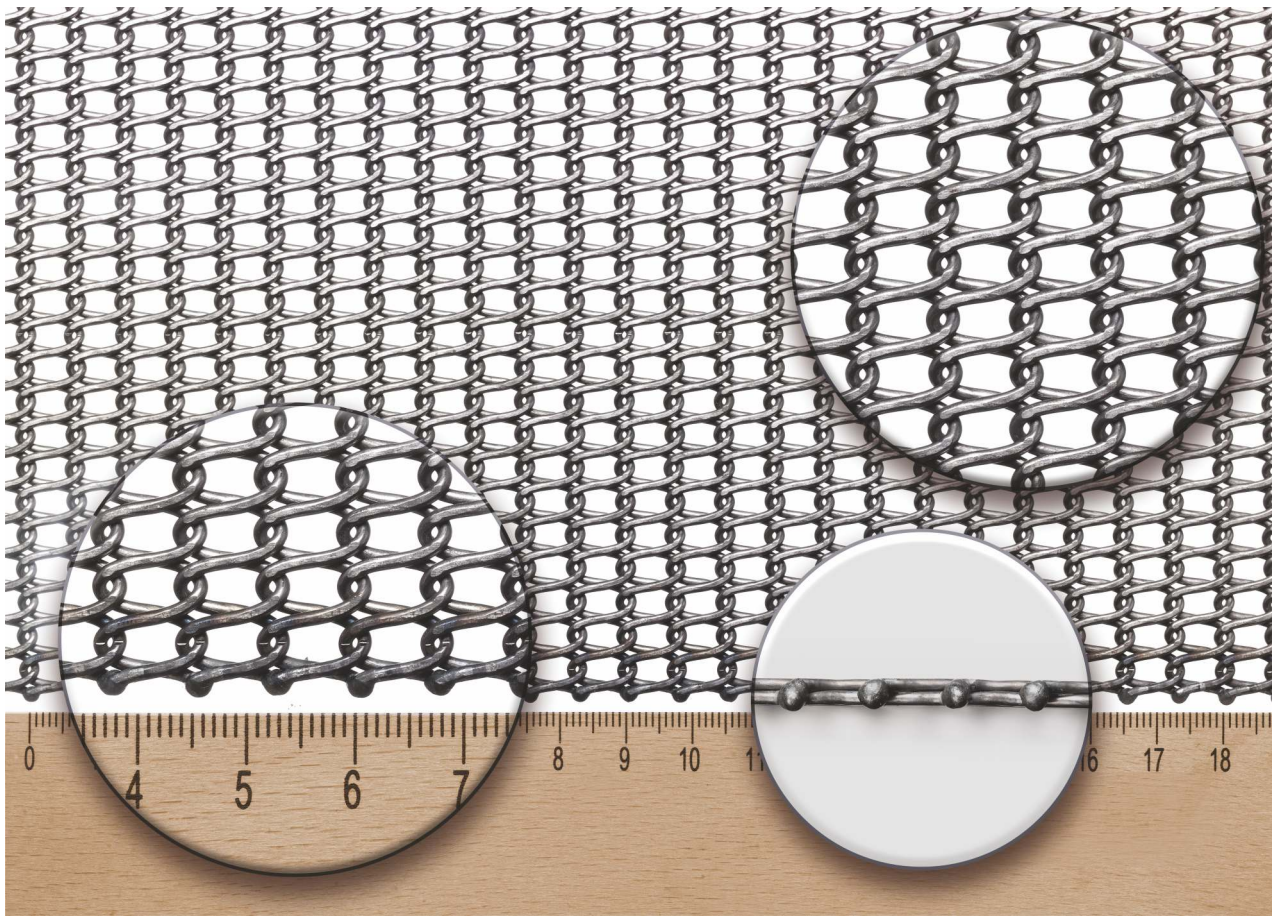

Rolled baking oven belts, also known as Z-Belts, are made of round wire spirals with very narrow and equal tolerances. The coiling direction of the spiral is changed with each wire, while they are intermeshed in pairs into each other (i.e. „double weaving“). The wire fabric is rolled flat first with greatest care before the belt is cut to width and the edges are spot welded. With this a very smooth, equal and angular belt structure is achieved with the required stability whilst retaining sufficient flexibility.

For producing baked durables of all kinds of hard and soft biscuits in particular, rolled baking oven belts are preferred to be used instead of solid steel belts or heavy weight multiple spiral belts, if the dough does not require a completely impervious belts, if the dough does not require a completely impervious belt. Compared with other wire mesh belts, rolled baking oven belts have several advantages of being thinner and lighter in weight plus they have an even and smooth surface. So the baked goods rest on a flat surface with less risk of breakage and packing is facilitated, since the bottom side of the product is smooth.



Compared with solid steel or multiple spiral belts our rolled baking oven belts allow gases in the product to escape also downward during the baking process, so that no unwanted bubbles will appear at the reverse side of the product. Moreover, the bottom side shows an appealing characteristic pattern.

This excellent air permeability for our belts ensures perfect heat circulation, more economic heat management of the oven and baking processes can often be made faster.



## Belt types and technical data for Rolled Baking Oven Belts

Type	F 4012	F 4015	F 4018	F 6014	F 2510
Comparable with	~ Z47	~ Z47R	~ Z47RR	~ Z48	~ Z28
Wire diameter	1,2 mm	1,5 mm	1,8 mm	1,4 mm	1,0 mm
Original mesh opening	4,0 mm	4,0 mm	4,0 mm	6,0 mm	2,5 mm
Open area	~ 32,5 %	~ 27,5 %	~ 22,0 %	~ 39,0 %	~ 30,5 %
Belt thickness	~ 2,1 mm	~ 2,7 mm	~ 3,4 mm	~ 2,5 mm	~ 1,8 mm
Spiral pitch	~ 3,9 mm	~ 4,5 mm	~ 5,2 mm	~ 5,0 mm	~ 3,5 mm
Weight per qm	~ 7,4 kg	~ 10,0 kg	~ 14,5 kg	~ 7,2 kg	~ 6,3 kg
No. of meshes over 1 m width	ø 267	ø 215	ø 199	ø 200	ø 298
Maximum belt width	1800 mm	1900 mm	1600 mm	1600 mm	1500 mm

## CLEANBELT®

### Build-in Situation

The arrangement of the CLEANBELT system together with existing brushes is to be done as per the sketch shown on the right.

Between CLEANBELT and brushes there must be no rollers for support or whatsoever. Otherwise the broken dirt layer would be pressed back into the meshes of the baking oven belt. For an optimum cleaning result there should be first a (self running) coarse brush from above and then a fine brush from below (motorized to run in counter direction).

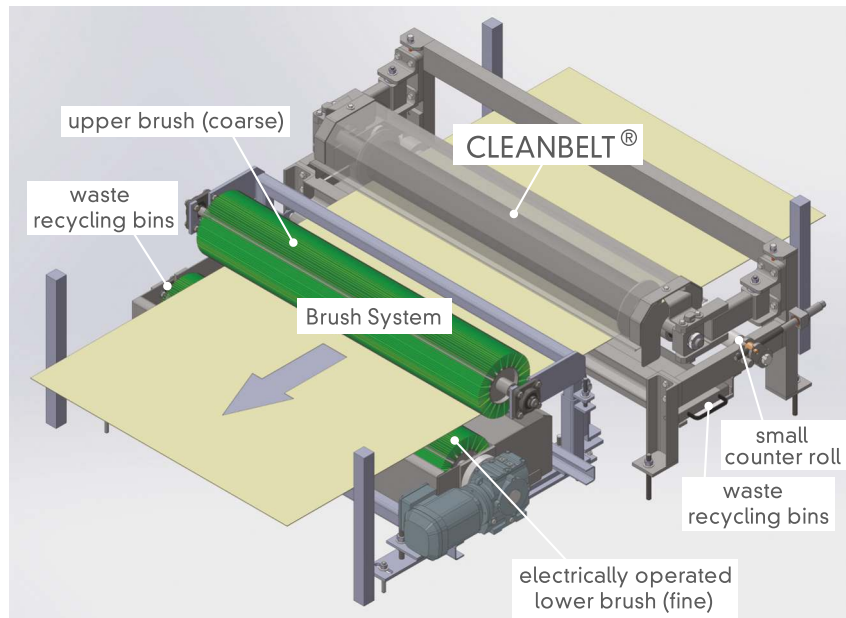

### Advantages

- The system works continuously and mechanically nearly maintenance free (only regular cleaning by compressed air or jet water)
- Additional manual cleaning of the baking oven belt is either no more necessary or reduced to a minimum at much greater intervals
- Improved oven's heat management at reduced costs
- Considerably reduced energy consumption for heating
- Longer operational life time, since no more belt changes because of dirt
- Suitable for several belt life time cycles
- Easy installation since no electric components involved
- Investment pays off in a short time

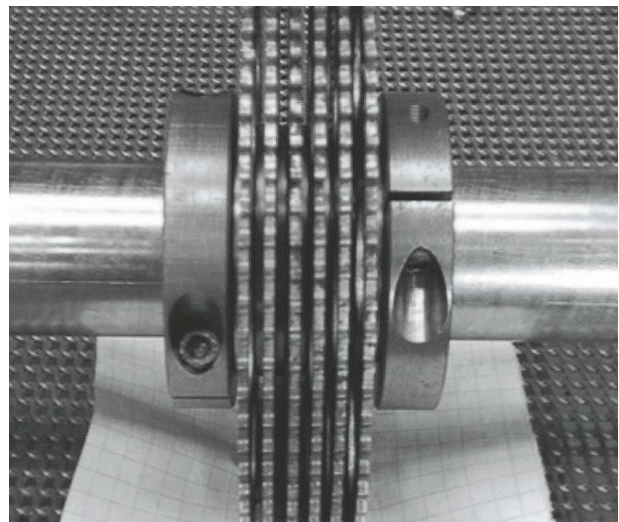





## Contacts

### EURO SITEX s.r.o.

K Podlesí 630  
261 01 Příbram VI  
Czech Republic

Telephone: +420 318 494 117  
Mobile: +420 603 527 493  
Fax: +420 318 494 160  
Email: [vachata@eurositex.cz](mailto:vachata@eurositex.cz)  
Internet: [www.eurositex.cz](http://www.eurositex.cz)

Company ID: 47544490  
Tax ID: CZ47544490

The Company is registered within the Commercial Register  
administered by the Municipal Court in Prague, Section C, File 26863



### Regional representation

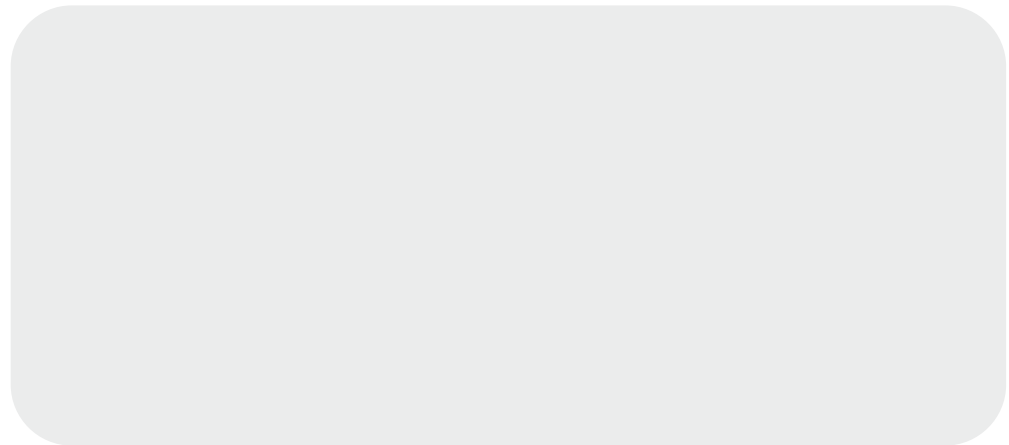

Contact us for on-site consultation by our experienced field engineers.  
For baking tests we would be more than pleased to furnish you with appropriate belt sample pieces.